



COMPACT 10 RTE COMPACT 12 RTE



Outstanding performance, both inside and outside

- Suitable for all terrains allowing the operator to work without noise and fumes
- Tight turning radius allowing an excellent manoeuvrability in confined areas
- Foam filled and non-marking tires with rough terrain profile
- Ground clearance of 25 cm
- Load capacity up to 565 kg (C10 RTE)
- Driveable at full height (C10 RTE)
- Long working cycles

Robust, reliable, easy to maintain

Haulotte 



COMPACT 10/12 RTE

ELECTRIC SCISSOR LIFTS

TECHNICAL DATA

Compact 10 RTE

Compact 12 RTE

| | | |
|---|--------------------|--------------------|
| Working height | 10.28 m | 12.06 m |
| Platform height | 8.28 m | 10.06 m |
| Maximum drive height | 8.28 m | 8.28 m |
| Lift capacity - inside | 565 kg (3 pers.) | 450 kg (3 pers.) |
| Lift capacity - outside | 565 kg (3 pers.) | 450 kg (3 pers.) |
| Lift capacity on the extension | 150 kg | 150 kg |
| Platform length - outside | 2.45 m | 2.45 m |
| Platform length - extended | 3.7 m | 3.7 m |
| Length - extension | 1.2 m | 1.2 m |
| G Platform width - outside | 1.45 m | 1.45 m |
| Storage height | 1.59 m | 1.71 m |
| C Height - stowed | 2.44 m | 2.56 m |
| B Overall width | 1.78 m | 1.78 m |
| A Length | 2.64 m | 2.64 m |
| D Wheelbase | 1.84 m | 1.84 m |
| E Ground clearance - Deployed potholes | N/A | N/A |
| Drive speed | 0,8 - 5,8 km/h | 0.8 - 5.8 km/h |
| Gradeability | 25 % | 25 % |
| Tilt | 3 ° | 3 ° |
| Lift / lower speed | 35 s / 35 s | 43 s / 43 s |
| Turning radius - outside | 3.73 m | 3.73 m |
| Non-marking tires | 26x12-12 | 26x12-12 |
| Batteries | 48 V - 255 Ah (C5) | 48 V - 255 Ah (C5) |
| Hydraulic system capacity | 63 l | 63 l |
| Weight | 3 305 kg | 3 675 kg |

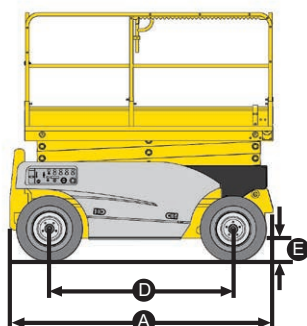
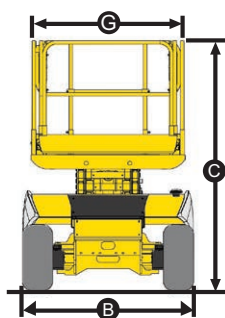

Compact 12 RTE

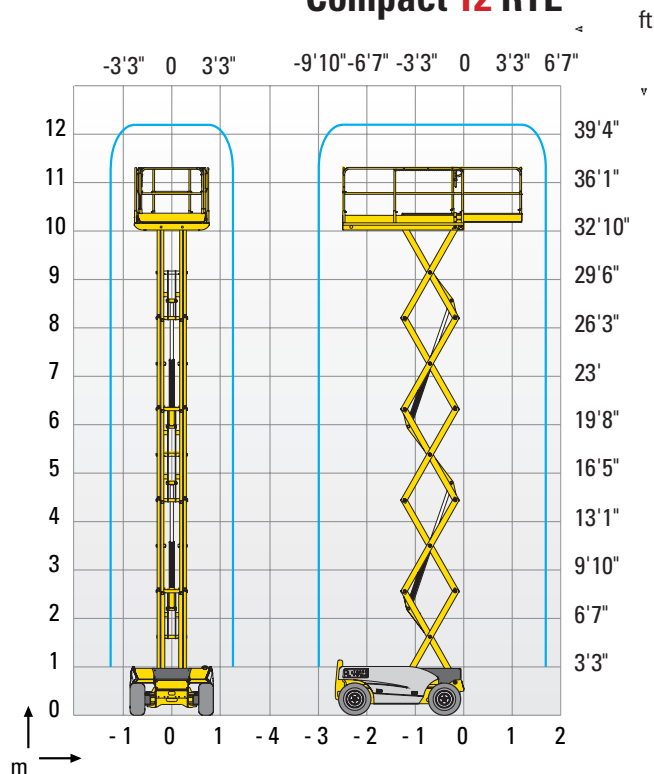

STANDARD EQUIPMENT

- Extended platform
- Horn
- Towing hooks
- Hydraulic brakes
- Manual platform lowering valve
- Load Management System in the platform
- Tilt controller
- Free wheeling device
- 2 wheel-drive
- Lanyard attachment points
- Battery charger with automatic stop
- Battery charge indicator
- Removable control box in platform
- Proportional lift and drive
- Hourmeter

OPTIONS AND ACCESSORIES

- Flashing light
- Travel alarm
- Power to platform
- Biodegradable hydraulic oil
- Outriggers (Increase machine weight by 240 kg)