

STAR 6 CRAWLER



GO EVERYWHERE

- > High-precision driving & smoothness
- > Intermediate supporting wheels in crawler track system
- > Ability to go through uneven grounds and water puddles
- > Dedicated forklift pockets

GREAT AGILITY IN CONFINED WORKING AREA

- > Compact machine: only 0.76 m width
- > Low turning radius
- > + 0.4 m platform extension
- > Platform with dedicated anti-slip step
- > Ergonomic & intuitive platform control box with battery level indicator

OPTIMAL TOTAL COST OF OWNERSHIP

- > 3-stage-cylinder mast: no chain & no cable
- > Direct electric drive brushless AC motors
- > Easy access to components (hoods and dedicated hand pump)
- > Onboard diagnostic: Haulotte Activ'Screen



STAR 6 CRAWLER

VERTICAL MASTS

TECHNICAL DATA

STAR 6 CRAWLER

| | |
|------------------------------|------------------------|
| Working height | 5.8 m |
| Platform height | 3.8 m |
| Lift capacity - inside | 200 kg (2 pers.) |
| Lift capacity - outside | 200 kg (1 pers.) |
| Platform size | 0.74 m x 1.0 m |
| Platform size with extension | 0.74 m x 1.44 m |
| A Length | 1.44 m |
| B Width | 0.76 m |
| C Height - stowed | 1.72 m |
| E Ground clearance | 6 cm |
| Drive speed proportional | 0.8 - 2.2 km/h |
| Turning radius - outside | 1.25 m |
| Tilt alarm | 1.5° / 3° |
| Gradeability | 25 % |
| Max driveable platf. height | 0.7 m |
| Rubber tracks - non marking | 180 x 72 x 43 |
| Power source | 2 x 12 V - 115 Ah (C5) |
| Hydraulic system capacity | 5 l |
| Weight | 1 175 kg |

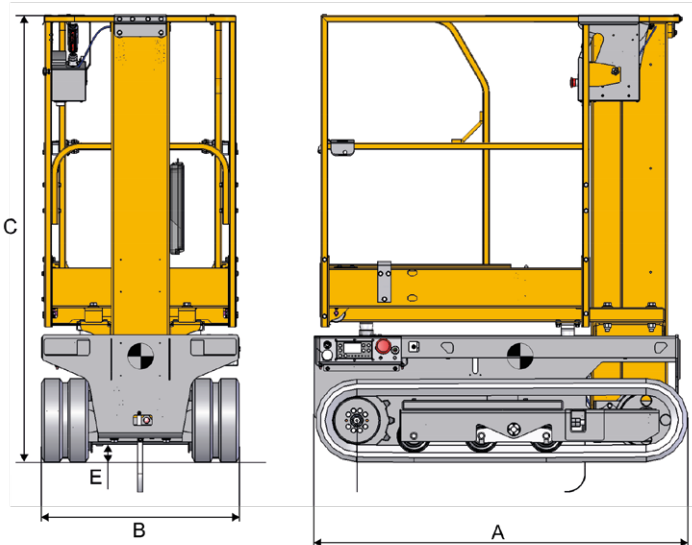

STANDARD EQUIPMENT

- > 24 V electric drive brushless AC motors
- > 20 A battery charger
- > 2x12 V - 115 Ah maintenance-free batteries
- > Battery level indicator
- > Haulotte Activ'Screen
- > Fork lifting pockets
- > Hoisting and lifting eyes
- > Door entry gate with lock
- > 2 drive speed
- > 2 steering and driving non marking rubber tracks
- > Hourmeter
- > Horn
- > Travel alarm
- > Emergency stop at cage and ground level
- > Lowering system
- > Handing pump for platform elevation
- > Control stations at cage and ground level
- > Mobile upper control box
- > 2 towing hooks
- > Platform extension deck + 0.4 m

OPTIONS AND ACCESSORIES

- > Lockable battery circuit breaker
- > Upper control box protection plastic cover
- > Joystick protection
- > Deadman pedal
- > Flashing light
- > Hydraulic oil for cold countries
- > Biodegradable oil

